

RESILIENT SEATED
BUTTERFLY VALVES



BRAY.COM

THE HIGH PERFORMANCE COMPANY

	Body Style	Size Range	Pressure Range	Page
Series 20	Wafer	1"-20" (25mm-500mm)	150 psi (10.3 bar)	6
Series 21	Lug	2"-20" (50mm-500mm)	150 psi (10.3 bar)	
Series 22	Wafer	2"-20" (50mm-500mm)	150 psi (10.3 bar)	8
Series 23	Lug	2"-20" (50mm-500mm)	150 psi (10.3 bar)	
	Double Flanged	24" (600mm)	150 psi (10.3 bar)	
Series 30	Wafer	2"-12" (50mm-300mm)	175 psi (12 bar)	10
		14"-20" (350mm-500mm)	150 psi (10.3 bar)	
Series 31	Lug	2"-12" (50mm-300mm)	175 psi (12 bar)	
		14"-20" (350mm-500mm)	150 psi (10.3 bar)	
Series 31H	Lug	2"-20" (50mm-500mm)	250 psi (17.2 bar)	11
Series 31U	Lug	2"-12" (50mm-300mm)	285 psi (20 bar)	12
Series 3A	Double Flanged	2"-12" (50mm-300mm)	175 psi (12 bar)	14
		14"-20" (350mm-500mm)	150 psi (10.3 bar)	
Series 3AH	Double Flanged	2"-20" (50mm-500mm)	250 psi (17.2 bar)	15
Series 32	Wafer	22"-36" (550mm-900mm)	75 psi (5.2 bar)	18
Series 33	Wafer	22"-36" (550mm-900mm)	150 psi (10.3 bar)	18
Series 35	Double Flanged	22"-120" (550mm-3000mm)	75 psi (5.2 bar)	20
Series 36	Double Flanged	22"-120" (550mm-3000mm)	150 psi (10.3 bar)	20
Series 35F	Double Flanged	32"-60" (800mm-1500mm)	75 psi (5.2 bar)	21
Series 36H	Double Flanged	22"-60" (550mm-1500mm)	232 psi (16 bar)	21
Actuators & Accessories				22

INTERNATIONAL COMPATIBILITY

Valve mounting top flanges meet ISO 5211 bolt circle standards for direct mounting of manual operators and power actuators. All Bray valves have extended necks which allow for at least 2" piping insulation.



ACTUATOR MOUNTING

All Bray actuators including handles, gear operators, pneumatic and electric actuators mount directly to Bray resilient seated valves. No brackets are required. This allows for simple installation in the field, minimizes possible misalignment and reduces overall height.

ISOLATION FROM LINE MEDIA

Bray's seat design and internal disc to stem connection isolates the line media from the body and stem.

INTERNAL DISC TO STEM CONNECTION

Series 30/31 Sizes 2" - 20" (50mm-500mm)

Bray offers Double "D" precision machined flats on the stem and in the disc. The Series 30/31 internal, non-wetted connections eliminate exposed external disc to stem connections.

The disc and the stem connection minimizes hysteresis and produces maximum strength engagements. All stem designs incorporate a blowout proof feature.

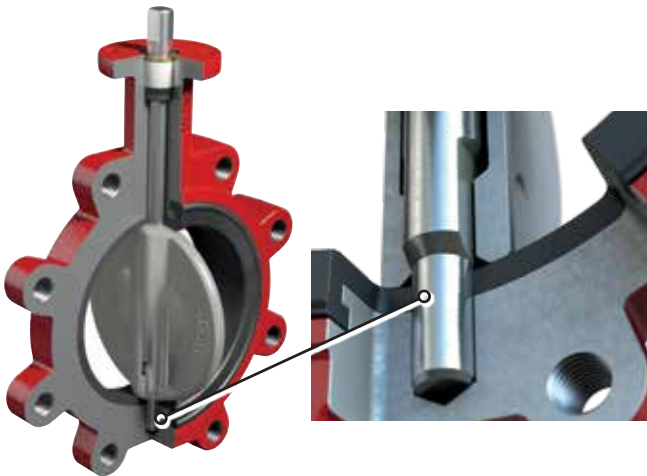
SEAT DESIGN

The seat is designed to seal with slip-on or weld-neck flanges and the molded o-ring eliminates the need for flange gaskets. The tongue and groove locks the seat in place and makes the valve dead end capable.

POLYESTER COATING

The Bray standard polyester body coating is a hard, gloss red finish. The polyester coating provides excellent corrosion and wear resistance.

Chemical Resistant

Resistant to dilute acids and alkalis, petroleum solvents, alcohols, greases and oils.

Weatherability

Resistant to humidity, water and ultraviolet radiation.

Abrasion and Impact Resistant
NYLON 11 COATING

Nylon 11 has superior corrosion resistance and has been used successfully in many applications such as water, cement, food and seawater.

Weatherability

Bray's Nylon 11 coating has been salt spray tested in excess of 2000 hours and used in seawater immersion service for over 30 years without any deterioration of the coating resulting in no corrosion to the coated metal components.

Abrasion and Impact Resistant
SEACORR® COATING

This proprietary coating for actuators provides superior product protection in corrosive conditions, tested to ASTM B-117.



Other customer specified coating materials are available. Please consult your local Bray representative for your specific application.

All Bray valves are pressure tested to 110% of rated pressure to assure bubble tight shutoff.

Series 20, 21, 3A, 30, 31, 32, 33, 35, 36

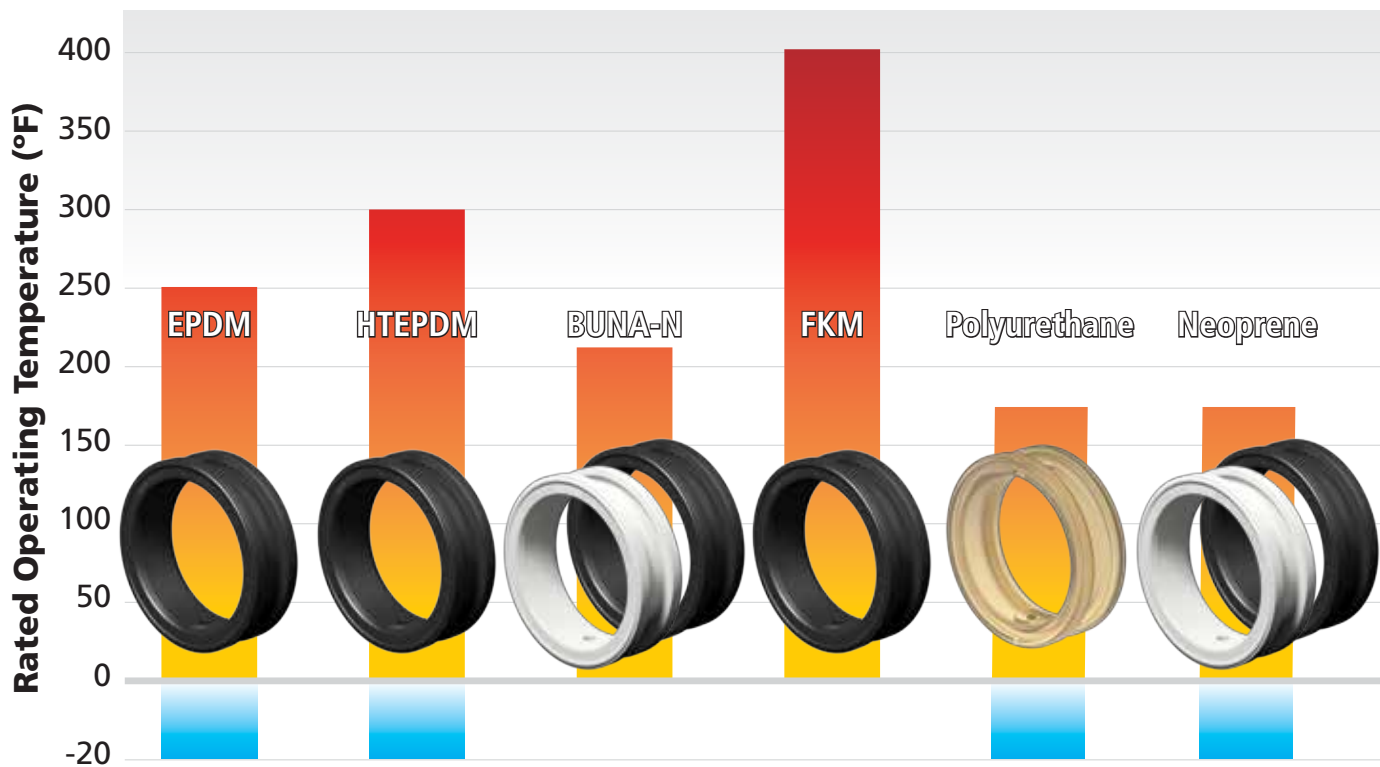

PEROXIDE CURED EPDM

-20°F to 250°F (-29°C to 121°C)

Bray's peroxide cured EPDM (Ethylene Propylene Diene Monomer) seats have a higher resistance to abrasion, lower compression set, and higher temperature capabilities than sulfur cured seats.

As a standard seat offering, Bray's peroxide cured EPDM is the most universal and economical seat material used in our resilient seated butterfly valves. All of Bray's peroxide cured EPDM seats are food grade and can be certified to NSF-61.

HTEPDM

-20°F to 300°F (-29°C to 150°C)

HTEPDM is a proprietary rubber blend offered by Bray to increase the thermal resistance properties of standard EPDM and is formulated to provide long term service at elevated temperatures for hot water. HTEPDM Food Grade seats are suitable for sanitary applications as well as standard industrial uses.

BUNA-N (Black or White)

0°F to 212°F (-18°C to 100°C)

BUNA-N is the commonly used name for Nitrile synthetic rubber. Nitrile is a copolymer of acrylonitrile and butadiene. BUNA-N is sometimes referred to as NBR, Nitrile, or Hycar. BUNA-N is a general purpose seat material particularly suitable for hydrocarbon service. BUNA-N is a standard Bray seat material and food grade is available for sanitary applications.

FKM

0°F to 400°F (-18°C to 204°C)

FKM is the ASTM D1418 designation for Fluorinated Hydrocarbon Elastomers (Fluoroelastomers) such as Viton® (DuPont). FKM has some outstanding characteristics such as improved acid, oil, and temperature resistance over other seat materials.

POLYURETHANE

-20°F to 175°F (-29°C to 80°C)

Polyurethane seats are primarily used because of their resistance to abrasive wear. Polyurethane can be used in a reasonably broad range of services and will withstand severe impact, recover its original shape after distortion and resist abrasion better than other elastomers.

NEOPRENE SEAT (Black or White)

0°F to 180°F (-18°C to 82°C)

Neoprene is an all-purpose polymer with desirable characteristics including high resiliency with low compression, resistance to vegetable and animal oil, and flame resistance. This sealing material is excellent for refrigerants, ammonia and Freon, and is principally used in pulp and (non-bleached) paper lines. Neoprene is not recommended for strong oxidizing acids, chlorinated solvents, esters, ketones, aromatic hydrocarbons or hydraulic fluids. White neoprene is generally used in sanitary applications while the black grade provides better abrasion and oil resistance.

Series 20, 21

Series 22, 23

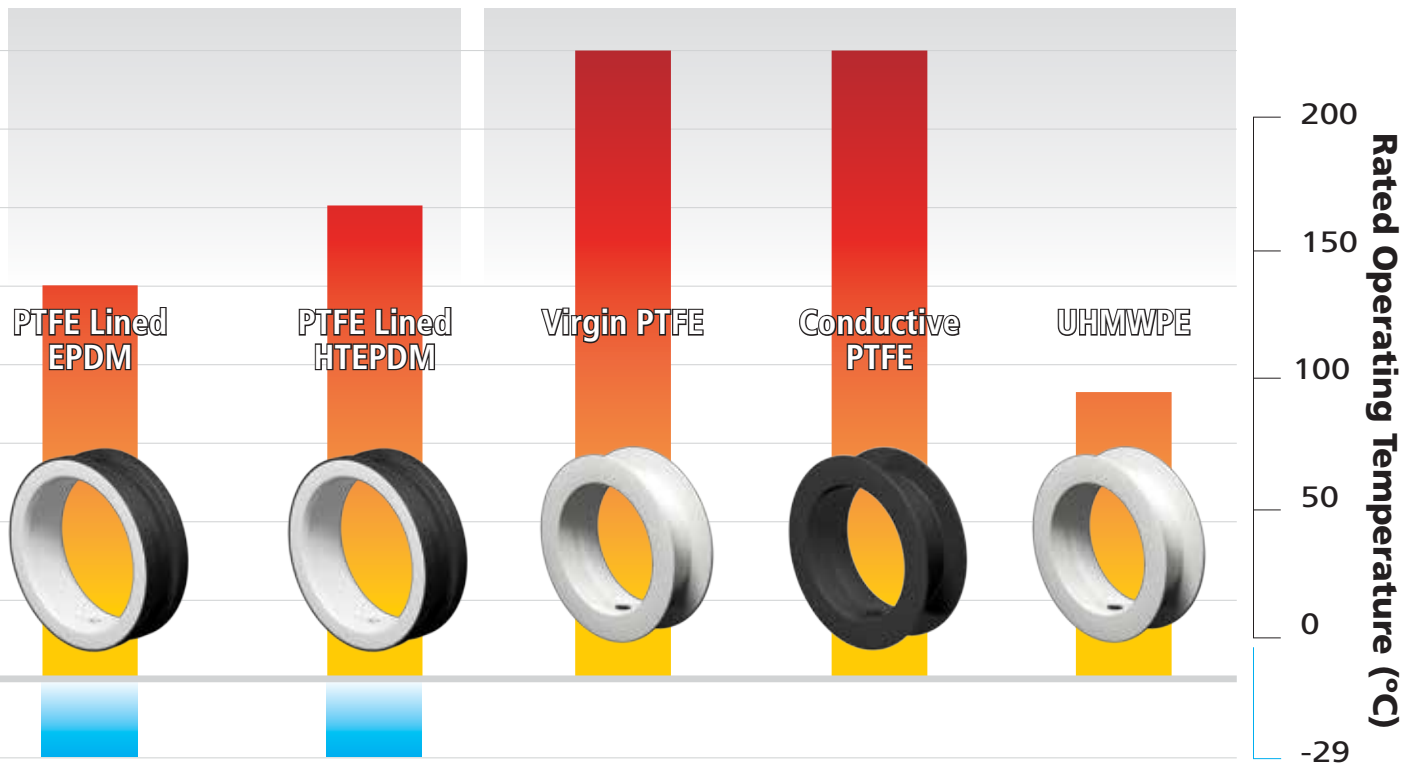

PTFE LINED EPDM

-20°F to 250°F (-29°C to 121°C)

PTFE lined EPDM seats consist of a PTFE liner which forms the flange sealing faces and the flow way of the seats which are molded on to EPDM elastomer backings. Only the inert, non-stick PTFE liner surface is exposed to the line media. The EPDM backing acts as a resilient support to the relatively rigid PTFE. These seats are generally used in corrosive services.

PTFE LINED HTEPDM

-20°F to 300°F (-29°C to 150°C)

PTFE lined HTEPDM seats consist of a PTFE liner which forms the flange sealing faces and the flow way of the seats which are molded on to HTEPDM elastomer backings. HTEPDM is a proprietary rubber blend offered by Bray to increase the thermal resistance properties of standard EPDM and is formulated to provide long term service at elevated temperatures.

VIRGIN PTFE

0°F to 400°F (-18°C to 204°C)

All Bray PTFE seats and encapsulated discs are isostatically molded from pure, virgin PTFE material to meet Bray's stringent material requirements. PTFE's inherent molecular bonding strength gives our seats an excellent chemical, high temperature, and tear resistance. Bray's sintered PTFE offers low permeability properties to provide optimum protection against aggressive line medias.

CONDUCTIVE PTFE

0°F to 400°F (-18°C to 204°C)

Bray's conductive PTFE seats and discs are available for installation in areas of the plant where explosion protection is important. This material was designed to prevent harmful electrostatic discharge. Bray has combined electrostatic discharge protection and the excellent chemical resistance properties of PTFE. The seat and the disc have a minimum conductive PTFE thickness of 1/8" (3 mm) which provides optimum protection against permeation of the line media.

UHMWPE

0°F to 185°F (-18°C to 85°C)

UHMWPE seats and discs feature exceptional chemical resistance and are the ideal choice for highly abrasive chemical applications. The natural ability of the UHMWPE's high molecular weight to repel solids prevents in-line particles from damaging the valve's seat surfaces.

Seat material availability depends on valve size and series. Please consult your local Bray representative for your specific application as the pressure and temperature of service also affect seat life and performance.

The Series 20/21 valve surpasses the high standards required in sanitary applications. The disc geometry provides superior inherent flow characteristics and capabilities.

- Sanitary and chemical applications
- One piece disc/stem
- Low pressure drop, High Cv

PRESSURE RATINGS

BIDIRECTIONAL BUBBLE TIGHT SHUT OFF Downstream flanges and disc in closed position			
Resilient Seated	Metal Disc/Stem	1"-20" (25-500mm)	150 psi (10.3 bar)
	Resilient Coated Disc/Stem	2"-20" (50-500mm)	100 psi (7 bar)
PTFE Seated	Metal Disc/Stem	2"-12" (50-300mm)	150 psi (10.3 bar)
	PTFE Coated Disc/Stem	2"-12" (50-300mm)	100 psi (7 bar)
DEAD END SERVICE Lug bodies, no downstream flanges and disc in closed position			
All Valves		2"-12" (50-300mm)	75 psi (5.2 bar)
		14"-20" (350-500mm)	50 psi (3.4 bar)
BODY: 150 psi (10.3 bar) CWP			

VELOCITY LIMITS FOR ON/OFF SERVICES

FLUIDS: 30 ft/sec (9 m/s)	GASES: 175 ft/sec (54 m/s)
---------------------------	----------------------------



- 1 – STEM BUSHING:** Non-corrosive, heavy duty acetal bushing absorbs actuator side thrust.
- 2 – STEM SEAL:** Double “U” cup seal design is self-adjusting and gives positive sealing in both directions.
- 3 – DISC/STEM:** One piece design. The disc edge is spherically machined and hand polished to produce a bubble tight shutoff, minimum torque, and longer seat life. For erosion and abrasion resistance, the one piece disc/stem is available encased in either EPDM or BUNA-N.
- 4 – PRIMARY AND SECONDARY SEALS:** These seals prevent line media from coming in contact with the stem or body. Primary seal is achieved by an interference fit of the molded seat flat with the disc hub. Secondary seal is created because the stem diameter is greater than the diameter of the seat stem hole.
- 5 – SEAT:** Bray’s tongue and groove seat design provides complete isolation of flowing media from the body. The seat also features a molded o-ring which eliminates the need of flange gaskets.
- 6 – BODY:** Two piece wafer or lug style allows for ease of assembly and maintenance.
- 7 – BODY COATINGS:** For excellent corrosion resistance, Nylon 11 coating is standard for 1” - 8” valves and available on larger sizes upon request. Polyester coating is standard for 10” -20” bodies.



MATERIAL SELECTION OPTIONS

BODY MATERIAL	DISC/STEM MATERIAL	SEAT MATERIAL
Cast Iron*	316 Stainless Steel*	EPDM Food Grade*
Ductile Iron*	Hastelloy® C-22	BUNA-N Food Grade*
316 Stainless Steel	PTFE molded over stainless steel	HTEPDM
Aluminum	EPDM molded over stainless steel	White BUNA-N Food Grade
	BUNA-N molded over stainless steel	FKM*
	Halar® coating over stainless steel	PTFE Lined EPDM
		PTFE Lined HTEPDM

*Standard Option

*FKM is the ASTM D1418 designation for fluorinated hydrocarbon elastomers (also called fluoroelastomers).

Halar® is a registered trademark of Solvay Solexis, Inc.

Hastelloy® is a registered trademark of Haynes International, Inc.

Material availability depends on valve size and series. Other materials are available. Please consult your local Bray representative for your specific application.

Extensive field research and engineering have developed this design which provides bubble tight shutoff and high Cv values. The Series 22/23 features a stainless steel disc that can be encapsulated in PTFE, PFA, or UHMWPE to fit a wide range of customer applications. The PTFE seat is isostatically molded to provide superior chemical resistance.

PRESSURE RATINGS

BIDIRECTIONAL BUBBLE TIGHT SHUT OFF Downstream flanges and disc in closed position		
All Valves	2"-24" (50-600mm)	150 psi (10.3 bar)
DEAD END SERVICE Lug bodies, no downstream flanges and disc in closed position		
All Valves	2"-12" (50-300mm)	75 psi (5.2 bar)
	14"-24" (350-600mm)	50 psi (3.4 bar)
BODY: 150 psi (10.3 bar) CWP		

VELOCITY LIMITS FOR ON/OFF SERVICES

FLUIDS: 30 ft/sec (9 m/s)	GASES: 175 ft/sec (54 m/s)
----------------------------------	-----------------------------------

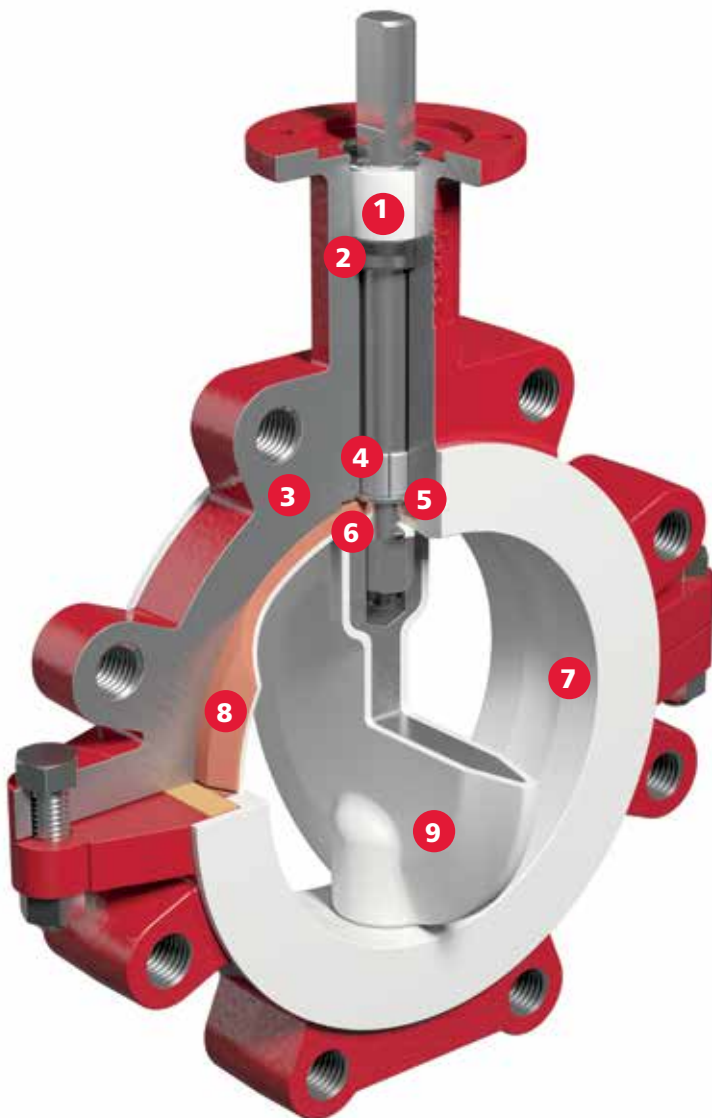

- 1 – UPPER STEM BUSHING:** An upper stem bushing, retained by a stainless steel ring, is provided to absorb actuator side thrusts and is acetal as standard or PTFE as an option.
- 2 – UPPER STEM SEAL:** Keeps environmental contaminants from entering the stem bore.
- 3 – BODY:** Bodies are two piece wafer or lug style and are epoxy coated. All bodies meet full ASME Class 150 OR DIN 3840 flange drilling requirements (24" body is double flanged).
- 4 – BEARINGS:** PTFE impregnated steel bearings provided for the precision alignment of the upper and lower stem.
- 5 – BLOWOUT PROOF STEM:** A shoulder is machined into the upper stem. The stem and the disc are pressed together during assembly creating a positive stem to disc connection.
- 6 – PRIMARY SEAL:** The primary seal is achieved by an interference fit between the extra wide disc hubs and contoured seat.
- 7 – SEAT DESIGN:** The unique seat geometry lowers seating and unseating torque while reducing wear on the contacting parts.
- 8 – SEAT ENERGIZER:** A resilient seat energizer extends completely around the seat, including the disc hub providing uniform force sufficient for bubble tight shutoff
- 9 – DISC:** The encapsulated disc has 1/8" (3 mm) minimum thickness of virgin PTFE or PFA lined over stainless steel.

Seal Capsule

The secondary seal is achieved using a seal capsule which fully isolates the valve body and stem from the line media. The seal capsule is made of a virgin PTFE enclosing the internal energizer. The capsule fits into grooves machined in the upper and lower disc hubs. When compressed between the disc and seat during assembly, the capsule becomes energized, exerting both upward and downward pressure on disc and seat surfaces.

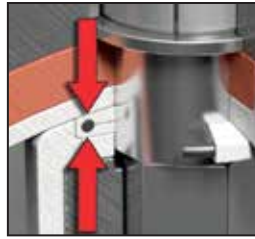

Body Seals

Reinforced PTFE gaskets are placed between the body halves. These bidirectional seals eliminate contamination from external environmental conditions and potential leak paths from the line media.

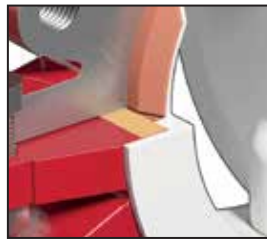

Accessories

Tapped port can be provided in the body neck below the stem seal for fugitive emissions detection.

Grounding cable is offered to protect against static charge build-up. The cable mounts to the valve body.



MATERIAL SELECTION OPTIONS

COMPONENT	MATERIAL	COMPONENT	MATERIAL
Body	Ductile Iron [†]	Bushing	Acetal [†]
	Stainless Steel		PTFE
	Carbon Steel	Upper Stem Seal	BUNA-N [†]
Disc	Stainless Steel [†]		FKM [*]
	PTFE molded over stainless steel [†]	Seal Capsule	PTFE / FKM
	PFA molded over stainless steel	Bearing	PTFE / Steel
	UHMWPE molded over stainless steel	Seat Energizer	Silicone [†]
	Hastelloy [®]		FKM [*]
Upper Stem	17-4 PH Stainless Steel	Body Seal	Reinforced PTFE
Lower Stem	17-4 PH Stainless Steel		
Seat	PTFE [†]		
	Conductive PTFE		
	UHMWPE		

[†]Standard Option

^{*}FKM is the ASTM D1418 designation for fluorinated hydrocarbon elastomers (also called fluoroelastomers).

Hastelloy[®] is a registered trademark of Haynes International, Inc.

Material availability depends on valve size and series. Other materials are available. Please consult your local Bray representative for your specific application.

The Bray Series 30/31 features a high strength one piece stem design utilizing an efficient internal disc to stem connection. This resilient seated butterfly valve provides a primary and secondary seal between the disc and seat as well as the stem and seat which ensures the total encapsulation of the line media and zero external leakage.

PRESSURE RATINGS

BIDIRECTIONAL BUBBLE TIGHT SHUT OFF – Standard Disc*		
Downstream flanges and disc in closed position		
Series 30/31	2"-12" (50-300mm)	175 psi (12 bar)
Standard Disc*	14"-20" (350-500mm)	150 psi (10.3 bar)
DEAD END SERVICE – Lug Bodies and Standard Disc*		
No downstream flanges and disc in closed position		
Series 31	2"-12" (50-300mm)	75 psi (5.2 bar)
	14"-20" (350-500mm)	50 psi (3.4 bar)
BODY: 250 psi (17.2 bar) CWP		

*For low pressure (50 psi) applications, Bray offers a standard reduced disc diameter to decrease seating torques and extend seat life, thus increasing the valve's performance and reducing actuator costs.

VELOCITY LIMITS FOR ON/OFF SERVICES

FLUIDS: 30 ft/sec (9 m/s)	GASES: 175 ft/sec (54 m/s)
----------------------------------	-----------------------------------



- 1 – STEM RETAINING ASSEMBLY:** The stem is retained in the body by means of a unique stainless steel Spirolox® retaining ring, a thrust washer and two C-rings, manufactured from brass as standard, stainless steel upon request.
- 2 – STEM BUSHING:** Non-corrosive, heavy duty acetal bushing absorbs actuator side thrust.
- 3 – STEM SEAL:** Double “U” cup seal design is self-adjusting and gives positive sealing in both directions.
- 4 – PRIMARY AND SECONDARY SEALS:** These seals prevent line media from coming in contact with the stem or body. The primary seal is an interference fit of the molded seat flat with the disc hub. The secondary seal is created because the stem diameter is greater than the diameter of the seat stem hole.
- 5 – BODY:** One piece wafer or lug style. Polyester coating for excellent corrosion resistance. Nylon 11 coating is available as an option.
- 6 – SEAT:** Bray’s tongue and groove seat design provides complete isolation of flowing media from the body. The seat also features a molded o-ring which eliminates the use of flange gaskets.
- 7 – DISC:** Casting is spherically machined and hand polished to provide a bubble tight shutoff, minimum torque, and longer seat life. Bray’s resilient Nylon 11 coating comes as standard.
- 8 – STEM:** Precision double “D” disc to stem connection drives the disc without the need for screws or pins. The close tolerance, double “D” connection that drives the valve disc is an exclusive feature of the Bray valve. Disassembly of the Bray stem is just a matter of pulling the stem out of the disc.



MATERIAL SELECTION OPTIONS

BODY	DISC	STEM	SEAT
Cast Iron [†] Ductile Iron [†] Carbon Steel Aluminum	Nylon 11 Coated Ductile Iron [†] 316 Stainless Steel [†] Nickel Aluminum Bronze Coated Ductile Iron Halar [®] Coated Ductile Iron 304 Stainless Steel Duplex Stainless Steel Super Duplex Stainless Steel Hastelloy [®]	416 Stainless Steel [†] 304 Stainless Steel 316 Stainless Steel Monel [®] K500	BUNA-N Food Grade [†] EPDM Food Grade [†] FKM [*] White BUNA-N Food Grade Bonded EPDM Bonded BUNA-N

[†]Standard Option

^{*}FKM is the ASTM D1418 designation for fluorinated hydrocarbon elastomers (also called fluoroelastomers).

Monel[®] is a registered trademark of The International Nickel Company, Inc.

Halar[®] is a registered trademark of Solvay Solexis, Inc.

Hastelloy[®] is a registered trademark of Haynes International, Inc.



SERIES 31H

2"-20" (50mm-500mm)

Series 31H Lug valves are drilled and tapped to meet ASME Class 125/150 and PN16 flanges. Series 31H valves are designed for manual operation only.

PRESSURE RATINGS

BIDIRECTIONAL BUBBLE TIGHT SHUT OFF AND DEAD END SERVICE

2"-20" (50-500mm) 250 psi (17.2 bar)

BODY: 250 psi (17.2 bar) CWP

VELOCITY LIMITS FOR ON/OFF SERVICES

FLUIDS: 30 ft/sec (9 m/s) GASES: 175 ft/sec (54 m/s)

STANDARD MATERIAL SELECTIONS

Body	Cast Iron Ductile Iron
Disc	Nickel Aluminum Bronze Nylon 11 Coated Ductile Iron 316 Stainless Steel
Stem	416 Stainless Steel
Seat	Bonded EPDM Bonded BUNA-N

Material availability depends on valve size and series. Other materials are available. Please consult your local Bray representative for your specific application.

Bray offers this high pressure resilient seated butterfly valve to meet the requirements of today's industrial and marine markets. This valve is specifically designed for onshore and offshore fire protection. The Series 31U is designed to withstand high line velocities and pressure drops through the valve.

PRESSURE RATINGS

BIDIRECTIONAL BUBBLE TIGHT SHUT OFF AND DEAD END SERVICE	
2"-12" (50-300mm)	285 psi (20 bar)
BODY: 285 psi (20 bar) CWP	

VELOCITY LIMITS FOR ON/OFF SERVICES

FLUIDS: 30 ft/sec (9 m/s)	GASES: 175 ft/sec (54 m/s)
---------------------------	----------------------------

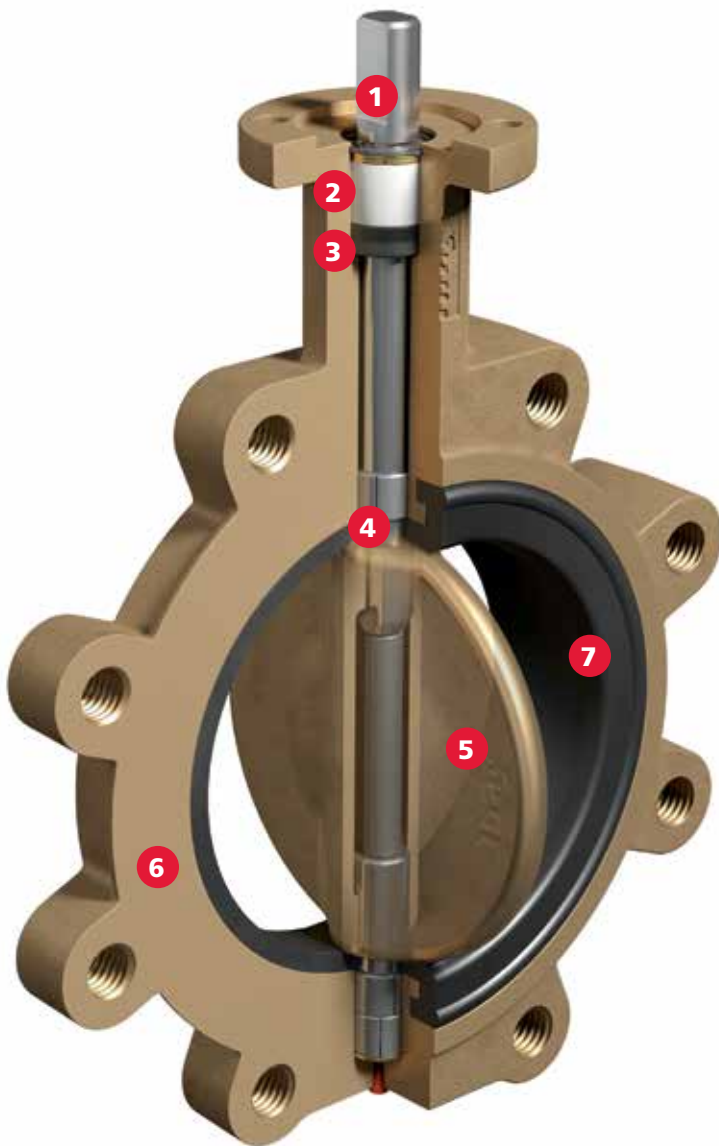

- 1 – STEM:** High strength upper and lower stems incorporate a close tolerance double "D" disk drive connection.
- 2 – STEM BUSHING:** Non-corrosive heavy duty acetal bushing absorbs actuator side thrust.
- 3 – STEM SEAL:** Patented stem retaining ring and C-rings prevent unintentional removal of the stem during field service.
- 4 – PRIMARY AND SECONDARY SEALS:** These seals prevent line media from coming in contact with the stem or body. The primary seal is an interference fit of the molded seat flat with the disc hub. The secondary seal is created because the stem diameter is greater than the diameter of the seat stem hole.
- 5 – DISC:** Casting is spherically machined and hand polished to provide bubble tight shut off with minimum torque and an extended seat life.
- 6 – BODY:** One piece lugged style flange configuration, with a choice of polyester coated ductile iron, polyester coated carbon steel or uncoated nickel aluminum bronze. All bodies can be drilled to be compatible with ASME 125/150, PN10/16 or other international flange standards.
- 7 – SEAT DESIGN:** Bray's bonded tongue and groove resilient seat design offers lower torque than many valves on the market today and provides complete isolation of flowing media from all valve components (excluding the disc) by a totally encasing design. The seat features a molded tangential o-ring eliminating any need for flange gaskets.



MATERIAL SELECTION OPTIONS

Body	Nickel Aluminum Bronze [†] Carbon Steel Ductile Iron
Disc	316 Stainless Steel [†] Monel [®] K500 [†] Nickel Aluminum Bronze [†]
Stem	17-4PH Stainless Steel Monel [®] K500 Stainless Steel
Seat	Bonded BUNA-N

[†]Standard Option

Monel[®] is a registered trademark of The International Nickel Company, Inc.

Material availability depends on valve size and series. Other materials are available. Please consult your local Bray representative for your specific application.

Bray's Series 3A/3AH valve is a double flanged design which can be used for dead end service and as a replacement for a gate valve. A major design advantage of the Series 3A/3AH is international compatibility. The same valve is compatible with most world flange standards – ASME Class 125/150, BS 10 Tables D and E, BS 4504 NP 10/16, DIN ND 10/16, AS 2129 and JIS10. In addition, the valves are designed to comply with ISO 5752 - Table 1 (EN 558 Table 14) face-to-face and ISO 5211 actuator mounting flanges. Therefore, one valve design can be used in many different world markets.

PRESSURE RATINGS

BIDIRECTIONAL AND DEAD END SERVICE BUBBLE TIGHT SHUT OFF Standard Disc*

Series 3A	2"-12" (50-300mm)	175 psi (12 bar)
Standard Disc*	14"-20" (350-500mm)	150 psi (10.3 bar)

BODY: 250 psi (17.2 bar) CWP

*For low pressure (50 psi) applications, Bray offers a standard reduced disc diameter to decrease seating torques and extend seat life, thus increasing the valve's performance and reducing actuator costs.

VELOCITY LIMITS FOR ON/OFF SERVICES

FLUIDS: 30 ft/sec (9 m/s)	GASES: 175 ft/sec (54 m/s)
----------------------------------	-----------------------------------



- 1 – STEM:** Precision double “D” disc to stem connection drives the disc without the need for screws or pins. The close tolerance, double “D” connection that drives the valve disc is an exclusive feature of the Bray valve. Disassembly of the Bray stem is just a matter of pulling the stem out of the disc.
- 2 – STEM RETAINING ASSEMBLY:** The stem is retained in the body by means of a unique stainless steel Spirolox® retaining ring, a thrust washer and two C-rings, manufactured from brass as standard, stainless steel upon request.
- 3 – STEM BUSHING:** Non-corrosive, heavy duty acetal bushing absorbs actuator side thrusts.
- 4 – STEM SEAL:** Double “U” cup seal design is self-adjusting, gives positive sealing in both directions, and prevents external substances from entering the stem bore.
- 5 – PRIMARY AND SECONDARY SEALS:** These seals prevent line media from coming in contact with the stem or body. The primary seal is an interference fit of the molded seat flat with the disc hub. The secondary seal is created because the stem diameter is greater than the diameter of the seat stem hole.
- 6 – DISC:** Casting is spherically machined and hand polished to provide a bubble tight shutoff, minimum torque, and longer seat life. Bray's resilient Nylon 11 coating comes as standard.
- 7 – SEAT:** Bray's bonded seat offers lower torque and provides complete isolation of flowing media from the body. The seat also features a molded O-ring which eliminates the use of flange gaskets.
- 8 – BODY:** One piece full flanged style. All bodies are drilled to be compatible with ASME 125/150, PN 10 or other international flange standards.



MATERIAL SELECTION OPTIONS

BODY	STEM	SEAT	DISC	
Cast Iron†	416 Stainless Steel†	Bonded EPDM†	Nylon 11 Coated Ductile Iron†	304 Stainless Steel
Ductile Iron†	304 Stainless Steel	Bonded BUNA-N†	316 Stainless Steel†	Duplex Stainless Steel
Carbon Steel	316 Stainless Steel	Bonded FKM*	Nickel Aluminum Bronze	Super Duplex Stainless Steel
	Monel® K500		Coated Ductile Iron	Steel
			Halar® Coated Ductile Iron	Hastelloy®

†Standard Option

*FKM is the ASTM D1418 designation for fluorinated hydrocarbon elastomers (also called fluoroelastomers).

Halar® is a registered trademark of Solvay Solexis, Inc.

Hastelloy® is a registered trademark of Haynes International, Inc.

Monel® is a registered trademark of The International Nickel Company, Inc.

SERIES 3AH

2"-20" (50mm-500mm)

Series 3AH Double Flanged valves are drilled and tapped to meet ASME Class 125/150 and PN16 flanges. Other flange drilling is available. Series 3AH valves are designed for manual operation only.



PRESSURE RATINGS

BIDIRECTIONAL BUBBLE TIGHT SHUT OFF AND DEAD END SERVICE

2"-20" (50-500mm) 250 psi (17.2 bar)

BODY: 250 psi (17.2 bar) CWP

VELOCITY LIMITS FOR ON/OFF SERVICES

FLUIDS: 30 ft/sec (9 m/s)

GASES: 175 ft/sec (54 m/s)

STANDARD MATERIAL SELECTIONS

BODY	STEM	SEAT	DISC
Ductile Iron	416 Stainless Steel	Bonded EPDM Bonded BUNA-N	Nickel Aluminum Bronze Nylon 11 Coated Ductile Iron 316 Stainless Steel

Material availability depends on valve size and series. Other materials are available. Please consult your local Bray representative for your specific application.



LARGE VALVE FEATURES AND BENEFITS

22" - 120" (550mm - 3000mm)

ISOLATION FROM LINE MEDIA

Bray's seat design and internal disc to stem connection isolates the line media from the body and stem.

INTERNAL DISC TO STEM CONNECTION

Bray offers splined and keyed disc to stem connections. These internal, non-wetted connections eliminate external disc to stem connections such as screws or taper pins.

Spline: Male splines on the stem and female in the disc.

Standard Sizes: 22" - 48" (550mm-1200mm)

Selected Sizes: 54" - 120" (1400mm-3000mm)

DOUBLE KEYED

Keyways are machined into the disc matching keys in the stem.

Selected Sizes: 54" - 120" (1400mm-3000mm)

Disassembly of Bray's internal connection is performed by simply pulling the stem out of the disc. All stem designs incorporate a blowout proof feature.

SEAT DESIGN

Bray's seat design provides complete isolation of flowing media from the body and stem with a totally encasing design. This seat is designed to seal with slip-on or weld-neck flanges.

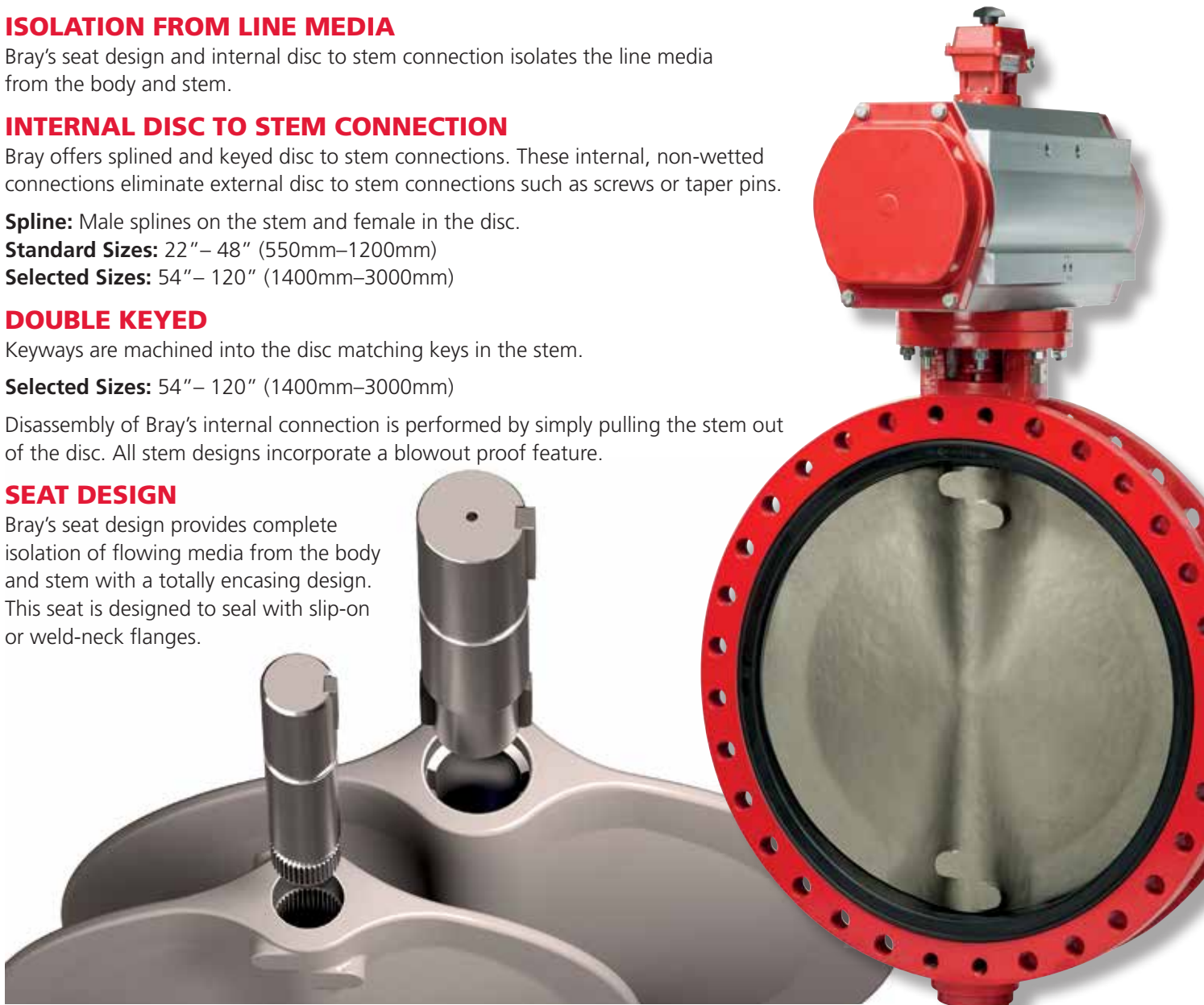

BRAY TONGUE AND GROOVE SEATS

Competitor Strip Seats expose the body, stem and disc stem hole to the line media, thus causing premature failure due to corrosion. Material costs are significantly increased for highly corrosive applications.

Bray Seats isolate the line media from contacting the body and stem, thus increasing service life and therefore lowering costs over the life of the valve.

Competitor Strip Seat

Bray's Seat

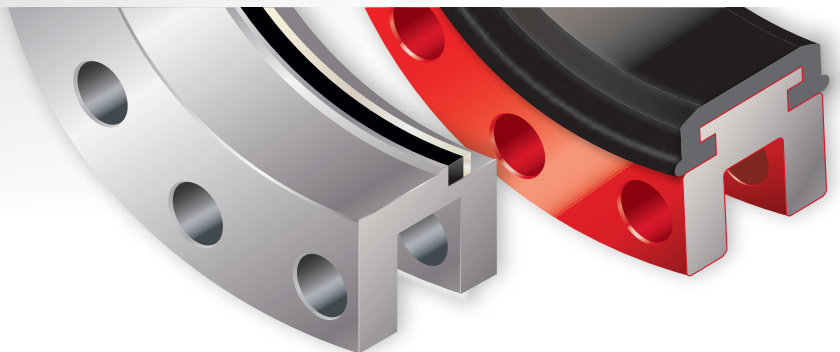

All Bray valves are pressure tested to 110% of rated pressure to assure bubble tight shutoff.

The Series 32/33 has many of the design features and benefits of the smaller Bray valves, such as high C_v ratings, minimum parts exposed to the line media, greater reliability and a proven record of long service life.

PRESSURE RATINGS

BIDIRECTIONAL BUBBLE TIGHT SHUT OFF Downstream flanges and disc in closed position		
Series 32 (Wafer)	22"-36" (550-900mm)	75 psi (5.2 bar)
Series 33 (Wafer)	22"-36" (550-900mm)	150 psi (10.3 bar)
BODY : 150 psi (10.3 bar) CWP		

VELOCITY LIMITS FOR ON/OFF SERVICES

FLUIDS: 30 ft/sec (9 m/s)	GASES: 175 ft/sec (54 m/s)
---------------------------	----------------------------



- 1 – THRUST BEARING:** Prevents side loading of the stem caused by actuator torque.
- 2 – BLOWOUT PROOF STEM:** A retaining ring, installed between the machined stem groove and gland retainer step, provides full retention of the stem in the unlikely event of internal stem failure.
- 3 – PRIMARY AND SECONDARY SEALS:** These seals prevent line media from coming in contact with the stem or body. The primary seal is an interference fit of the molded seat flat with the disc hub. The secondary seal is created because the stem diameter is greater than the diameter of the seat stem hole.
- 4 – BODY:** One piece wafer style. All bodies are designed to be compatible with ASME 125/150, PN 10 or other international flange standards.
- 5 – DISC:** High strength discs are spherically machined then hand polished and coated with Nylon 11. The symmetrical disc profile increases C_v values, reduces turbulence and increases pressure recovery.
- 6 – SEAT:** The replaceable tongue and groove seat to body retention method is the most advanced design in the industry. Molded o-ring eliminates the requirement of flange gaskets. The seat isolates the valve body and stem from line media and has been specifically designed to seal with slip-on or weld-neck flanges.
- 7 – STEM RETAINER:** The steel stem retainer locks the stem assembly together and assists in aligning the disc during assembly.
- 8 – STEM ASSEMBLY:** The upper and lower shafts provide a strong, positive connection to the disc and the tie-rod bolting design allows for better control of the disc to seat hub interferences.



MATERIAL SELECTION OPTIONS

BODY	DISC	STEM	SEAT	PACKING
Cast Iron [†] Ductile Iron [†] Carbon Steel 316 Stainless Steel	Nylon 11 Coated Ductile Iron [†] 316 Stainless Steel [†] 304 Stainless Steel Aluminum Bronze Monel® Hastelloy® Duplex Stainless Steel Super Austenitic Stainless Steel	416 Stainless Steel [†] 304 Stainless Steel 316 Stainless Steel 17-4 PH Stainless Steel Monel® Duplex Stainless Steel Super Austenitic Stainless Steel	EPDM [†] BUNA-N [†] FKM* Valves 54" (1400 mm) and larger are provided with bonded seats	BUNA-N BEARINGS Lubricant Impregnated Bronze PTFE encapsulated stainless steel THRUST BEARING Bronze

[†]Standard Option

*FKM is the ASTM D1418 designation for fluorinated hydrocarbon elastomers (also called fluoroelastomers).

Hastelloy® is a registered trademark of Haynes International, Inc.

Monel® is a registered trademark of The International Nickel Company, Inc.

Material availability depends on valve size and series. Other materials are available. Please consult your local Bray representative for your specific application.

The Series 35/36 valves provide the same robust features of the Series 32/33 valves while adding adjustable packing, increasing the maximum valve size offered to 120" (3000mm), and utilizing the flexible design of a fully flanged body. These valves hold to the Bray traditions of reliable performance and providing a long service life.

PRESSURE RATINGS

BIDIRECTIONAL BUBBLE TIGHT SHUT OFF Downstream flanges and disc in closed position		
Series 35 (Full Flanged)	22"-120" (550-3000mm)	75 psi (5.2 bar)
Series 36 (Full Flanged)	22"-120" (550-3000mm)	to 150 psi (10.3 bar)
DEAD END SERVICE No downstream flanges and disc in closed position		
Series 35 (Full Flanged)	22"-120" (550-3000mm)	30 psi (2.1 bar)
Series 36 (Full Flanged)	22"-120" (550-3000mm)	50 psi (3.4 bar)
BODY: Series 35, 36	150 psi (10.3 bar) CWP	

VELOCITY LIMITS FOR ON/OFF SERVICES

FLUIDS: 30 ft/sec (9 m/s)	GASES: 175 ft/sec (54 m/s)
----------------------------------	-----------------------------------



- 1 – BLOWOUT PROOF STEM:** A retaining ring, installed between the machined stem groove and gland retainer step, provides full retention of the stem in the unlikely event of internal stem failure.
- 2 – ADJUSTABLE PACKING SYSTEM:** Design allows for field adjustment of stem packing without removing manual operators or power actuators. The advanced, self-adjusting V-Type stem packing prevents external substances from entering the upper stem bore.
- 3 – UPPER AND LOWER STEM BEARINGS:** These PTFE/ stainless steel bearings protect the shaft and body from wear during pressurized cycles.
- 4 – PRIMARY AND SECONDARY SEALS:** These seals prevent line media from coming in contact with the stem or body. The primary seal is an interference fit of the molded seat flat with the disc hub. The secondary seal is created because the stem diameter is greater than the diameter of the seat stem hole.
- 5 – BODY:** One piece full flanged style. All bodies are drilled to be compatible with ASME 125/150, PN 10 or other international flange standards.
- 6 – DISC:** High strength discs are spherically machined then hand polished and coated with Nylon 11. The symmetrical disc profile increases CV values, reduces turbulence and increases pressure recovery.
- 7 – SEAT:** The replaceable tongue and groove seat to body retention method is the most advanced design in the industry. Molded o-ring eliminates the requirement of flange gaskets. The seat isolates the valve body and stem from line media.
- 8 – STEM RETAINER:** The steel stem retainer locks the stem assembly together and assists in aligning the disc during assembly.
- 9 – STEM ASSEMBLY:** The upper and lower shafts provide a strong, positive connection to the disc and the tie-rod bolting design allows for better control of the disc to seat hub interferences.



SERIES 35/36 FULL FLANGED MATERIAL SELECTION OPTIONS

BODY	DISC	STEM	SEAT
Cast Iron [†]	Nylon 11 Coated Ductile Iron [†]	416 Stainless Steel [†]	EPDM [†]
Ductile Iron [†]	316 Stainless Steel	304 Stainless Steel	BUNA-N
Carbon Steel	304 Stainless Steel	316 Stainless Steel	FKM [*]
316 Stainless Steel	Nickel Aluminum Bronze	17-4 PH Stainless Steel	Valves 54" (1400mm) and larger are provided with bonded seats
	Monel [®]	Monel [®]	
	Hastelloy [®]	Duplex Stainless Steel	
	Duplex Stainless Steel	Super Austenitic Stainless Steel	
	Super Austenitic Stainless Steel		

PACKING: BUNA-N

BEARINGS: Lubricant impregnated bronze, PTFE encapsulated stainless steel

THRUST BEARING: Bronze

[†]Standard Option

SERIES 35F

Bray Series 35F large diameter butterfly valves are designed specifically for high chloride services. Series 35F valves offer rugged reliability in a light weight design.

PRESSURE RATINGS

BIDIRECTIONAL BUBBLE TIGHT SHUT OFF Downstream flanges and disc in closed position	
32"-60" (800-1500mm)	75 psi (5.2 bar)
DEAD END SERVICE No downstream flanges and disc in closed position	
32"-60" (800-1500mm)	30 psi (2.1 bar)
BODY: 150 psi (10.3 bar) CWP	

VELOCITY LIMITS FOR ON/OFF SERVICES

FLUIDS: 30 ft/sec (9 m/s)	GASES: 175 ft/sec (54 m/s)
----------------------------------	-----------------------------------

STANDARD MATERIALS SELECTION

Body	Cast Iron, Ductile Iron
Disc	Hastelloy [®] Duplex Stainless Steel Super Austenitic Stainless Steel
Stem	304 Stainless Steel 316 Stainless Steel
Seat	Bonded EPDM Bonded BUNA-N
Packing	BUNA-N
Bearings and Thrust Bearing:	PTFE / Stainless Steel, Bronze



SERIES 36H

High pressure manual butterfly valves that meet many of today's requirements in the process industry. Series 36H large diameter, double flanged valves are rated for 232 psi (16 bar) bidirectional dead end service. Series 36H double flanged valves are drilled and tapped to meet ASME Class 125/150 and PN10 flanges. Series 36H valves are designed for manual operation only.

PRESSURE RATINGS

BIDIRECTIONAL BUBBLE TIGHT SHUT OFF Downstream flanges and disc in closed position	
22"-60" (550-1500mm)	232 psi (16 bar)
DEAD END SERVICE No downstream flanges and disc in closed position	
22"-60" (550-1500mm)	150 psi (10.3 bar)
BODY: 232 psi (16 bar) CWP	

VELOCITY LIMITS FOR ON/OFF SERVICES

FLUIDS: 30 ft/sec (9 m/s)	GASES: 175 ft/sec (54 m/s)
----------------------------------	-----------------------------------

STANDARD MATERIALS SELECTION

Body	Ductile Iron
Disc	Nylon 11 Coated, Ductile Iron Nickel Aluminum Bronze 316 Stainless Steel
Stem	17-4 PH Stainless Steel
Seat	Bonded EPDM Bonded BUNA-N
Packing	BUNA-N
Bearings and Thrust Bearing:	PTFE / Stainless Steel, Bronze



Material availability depends on valve size and series. Other materials are available. Please consult your local Bray representative for your specific application.

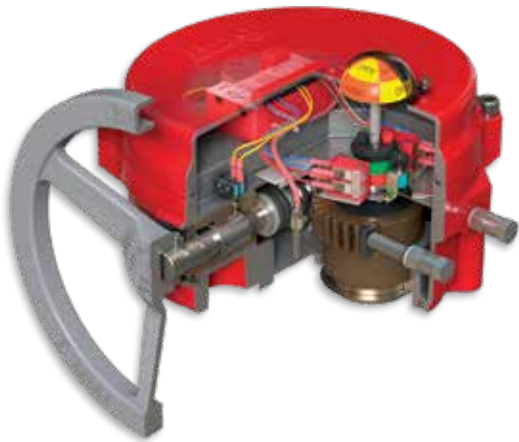

SERIES 70 ELECTRIC ACTUATOR

The Series 70 is a low profile, compact, and powerful actuator with customer-friendly features

- Manual declutchable handwheel
- Local high visibility dome position indicator
- Digital interface available
- Optional microprocessor based modulating control

Torque	300 to 18,000 lb-ins (34 - 2030 Nm)
Voltage	VAC: 24, 120, 220, VDC: 12, 24
Standard Enclosure	NEMA Type 4, 4X
Explosion Proof	NEMA Type 4, 4X and specifications for USA and Canadian hazardous locations Class I Div 1 & 2 Groups C & D Class II Div 1 & 2 Groups E, F, & G.



SERIES 92/93 PNEUMATIC ACTUATOR

Bray rack and pinion actuators available in double acting and spring return

- Standard units have anodized aluminum bodies with polyester coated end caps
- Seacorr coating for harsh environments
- Integral porting
- Internal bidirectional travel stops
- SIL 3 capable
- NAMUR accessory compatible

Torque	Double Acting up to: 44,130 lb-in (4,986 Nm) Spring End Torque up to: 14,173 lb-in (1,601 Nm)	
Pressure Range	40 - 140 psi (2.8 - 10 bar)	
Media	Dry Compressed Air/Inert Gas*	
Temperature Range	Standard:	-4°F to 200°F (-20°C to 93°C)
	Low:	-40°F to 176°F (-40°C to 80°C)
	High:	0°F to 300°F (-18°C to 149°C)
	Extreme High Temperature:	0°F to 482°F (-18°C to 250°C)



Extreme High Temperature Actuator



Stainless Steel Actuator



SERIES 98 SCOTCH YOKE PNEUMATIC ACTUATOR

Bray scotch yoke actuator for quarter turn rotary operation

- Compact design with a high torque to weight ratio
- Modular design offers easy configuration in the field
- Optional modular components: manual overrides, hydraulic dampener for fast acting operation, lockout/PST device
- Premium epoxy/polyurethane coating as standard
- Pressure Equipment Directive (PED) 97/23/EC compliant
- Standardized interfaces: ISO 5211, VDI/VDE 3845 for accessories
- Optional Seacorr coating for harsh environments
- SIL 3 capable

Torque	Double Acting up to:	885,000 lb-in (100,000 Nm)
	Spring Return (Spring End) up to:	445,261 lb-in (50,306 Nm)
Pressure Range	40 - 150 psi (2.8 - 10.3 bar)	
Media	Dry Compressed Air/Inert Gas*	
Temperature Range	Standard:	-4°F to 200°F (-20°C to 93°C)
	High Temperature:	Up to 300°F (149°C)
	Low Temperature:	Down to -50°F (-46°C)



SERIES 6A ELECTRO-PNEUMATIC POSITIONER

- Precision digital control
- Zero bleed design
- Compatible with rotary or linear actuators for single and double acting applications
- Various housing options available
- Precise, microprocessor driven flow control and advanced communication
- Non-contacting position sensor technology
- Integral volume booster
- Connective and preventative maintenance self-diagnostic checks



SERIES 6P P/P POSITIONER

- Pneumatic to pneumatic positioner for single and double acting actuators
- Rugged aluminum diecast housing for harsh environments
- Minimal setup time for zero and span adjustment
- Split range capabilities
- High visibility dome position indicator
- Optional 2 x SPDT mechanical switches



SERIES 5A AND SERIES 5B VALVE STATUS MONITORS

- Discrete status monitor for quarter turn rotary actuators
- NEMA 4, 4X and IP66 and IP67 ingress protection
- High visibility dome position indicator
- Up to 6 SPDT switches or non-contacting proximity switches
- Switches pre-wired to internal terminal block



SERIES 54 VALVE PROXIMITY SENSOR

- Dual proximity sensors for valve position
- NEMA 4, 4X and IP66, IP67, IP69K ingress protection available
- Available solenoid outputs
- 2 or 3 wire DC, AC/DC, intrinsically safe, and AS-i interface
- Pin connector or conduit versions available

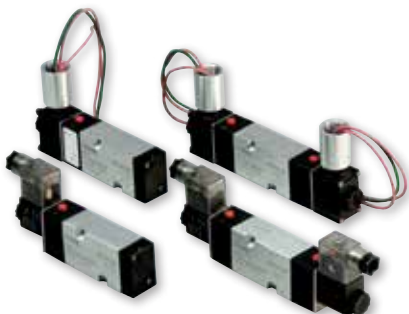

SERIES 63 HIGH FLOW 3 AND 4 WAY SOLENOID VALVES

- Weatherproof NEMA 4, 4X and explosion proof housings available
- Flying leads or DIN connectors
- Single or dual coil
- 5/2 or 3/2 Operation
- NAMUR mounted
- High flow up to 1.4 Cv
- Intrinsically safe versions available



THE HIGH PERFORMANCE COMPANY



BRAY INTERNATIONAL PRIMARY SALES AND SERVICE LOCATIONS

USA Houston, Texas	CHINA Hangzhou, Zhejiang	MEXICO Zapopan, Jalisco	RUSSIA Moscow
AFRICA Johannesburg	COLOMBIA Bogotá	MIDDLE EAST Dubai	SINGAPORE Ubi Techpark
BENELUX Heerhugowaard	FRANCE Voiron	PACIFIC Melbourne, Australia	SOUTH KOREA Seoul
BRAZIL Paulinia, Sao Paulo	GERMANY Krefeld	PERU Lima	SOUTHEAST ASIA Malaysia
CANADA Montreal	INDIA Vadodara	POLAND Oświęcim	UNITED KINGDOM Glasgow
CHILE Santiago	ITALY Milano		

FLOW-TEK

USA Houston, Texas
BRAZIL Paulinia, Sao Paulo
CHINA Hangzhou, Zhejiang

RITE CORPORATION

CANADA Montreal

VALVTRONIC

ARGENTINA Buenos Aires

AMRESIST

USA Houston, Texas

BRAY/VAAS

INDIA Chennai

KUGELHAHN MÜLLER

GERMANY Krefeld

HEADQUARTERS
Bray International, Inc.
 13333 Westland East Blvd.
 Houston, Texas 77041
 Tel: 281.894.5454
 bray.com

All statements, technical information, and recommendations in this bulletin are for general use only. Consult Bray representatives or factory for the specific requirements and material selection for your intended application. The right to change or modify product design or product without prior notice is reserved. Patents issued and applied for worldwide.

Bray® is a registered trademark of Bray International, Inc.

© 2018 Bray International. All rights reserved.

B-1050_EL_Resilient Seated Valves_1_2018